

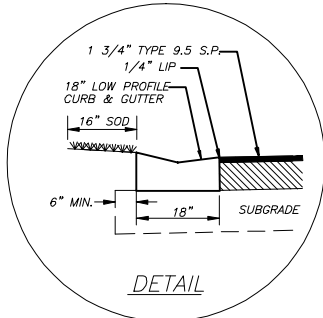

RIGHT-OF-WAY WIDTH: 50 FEET

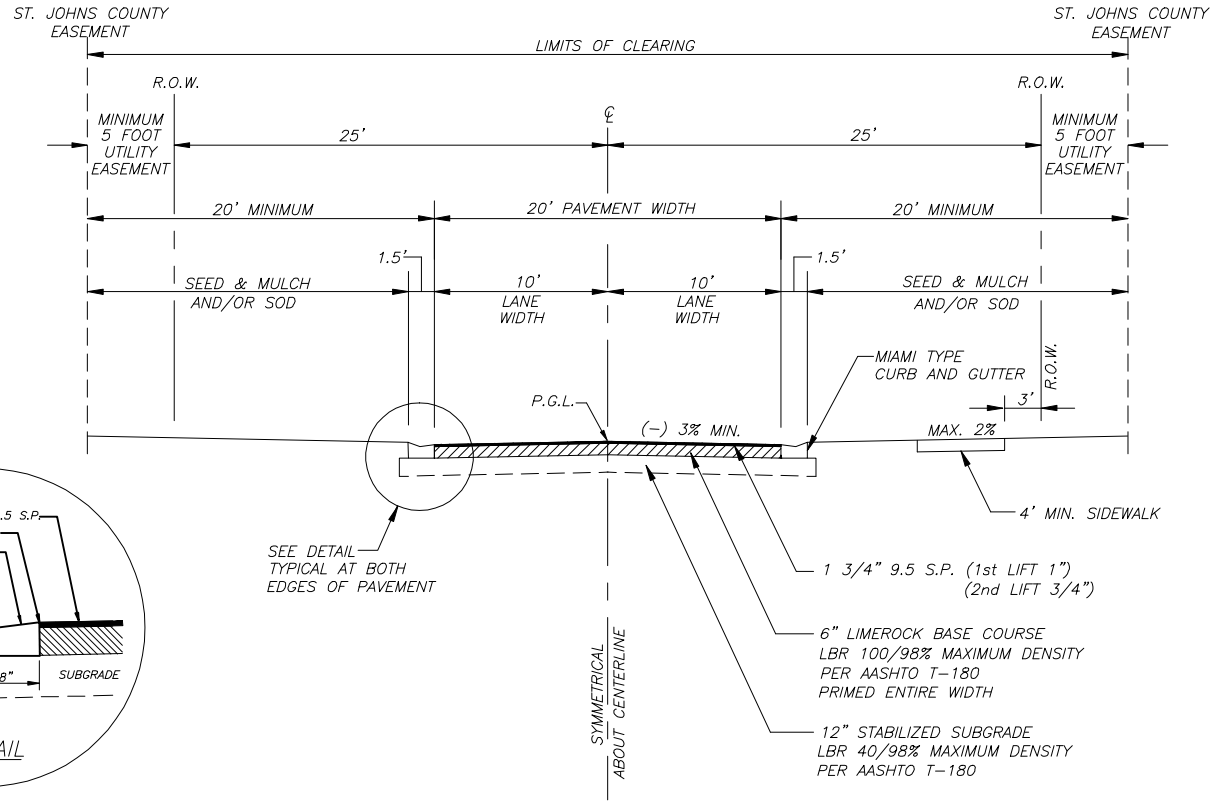

- NOTES:**
- OPTIONAL BASE MATERIALS MAY BE ACCEPTABLE UPON APPROVAL BY THE COUNTY ENGINEER
 - 9.5 S.P. SHALL BE FINAL ASPHALT COURSE PLACED
 - TYPICAL SECTION USE SHALL BE APPROVED BY THE COUNTY ENGINEER
 - PLATTED EASEMENTS DEDICATED TO THE COUNTY REQUIRED
 - GOLF CARTS MAY BE PERMITTED ON THIS ROADWAY TYPICAL SECTION WHEN PERMITTED THROUGH THE PROCESS IDENTIFIED IN ORDINANCE 2009-1 AND APPROVED BY THE COUNTY ENGINEER

TRAFFIC VOLUME < 1,500 AADT
RESIDENTIAL ROADS ONLY

STRUCTURAL NUMBER: 2.70

 <p>ST JOHNS COUNTY PUBLIC WORKS DEPARTMENT ENGINEERING DIVISION</p> <p>2740 Industry Center Road ST AUGUSTINE, FLORIDA 32084 Phone (904) 209-0110 • Fax. (904) 209-0140</p>	<p>REVISION</p> <p>10/09</p>
	<p>DESIGN DETAIL</p>

<p>DESIGN DETAIL</p> <p>LOCAL ROAD-2 LANE-50' R.O.W. TYPICAL CURB & GUTTER SECTION</p>
--

<p>EFFECTIVE DATE:</p> <p>DETAIL NO. 100</p> <p>APPROVED:</p> <p> H.P. TOMPKINS, JR., P.E. COUNTY ENGINEER</p>
